

Two-way Radios

User Guide



XTNi Non-Display Model

Motorola, the Stylized M Logo, and all other trademarks indicated as such herein are Trademarks of Motorola, Inc. Reg. U.S. Pat. & Tm. Off. © 2007 Motorola, Inc.
All rights reserved. Printed in the U.S.A.

CONTENTS

Contents	1
Computer Software Copyrights	4
Safety	5
Product Safety and RF Exposure Compliance	5
Batteries and Chargers Safety Information Operational Safety Guidelines	7
Radio Overview	8
Parts of the radio	8
ON/OFF/Volume Knob	9
Channel Selector Knob	9
Microphone	9
Antenna	9
LED Indicator	9
Side Buttons	9
The Lithium-Ion (Li-Ion) Battery	9
Batteries and Chargers	11
Battery Features and Charging Options ..	11

About the Li-Ion Battery	11
Battery Recycling and Disposal	12
Installing the Lithium-Ion (Li-Ion) Battery ..	13
Removing the Lithium-Ion (Li-Ion) Battery ..	13
Alkaline battery pack (optional accessory) ..	14
Installing Alkaline Battery Pack	14
Removing Alkaline Batteries	14
Power Supply, Adaptors and Drop-in Tray Charger	15
Installing Spring Action Belt Clip	16
Battery Life Information	16
Charging the Battery	17
Charging with the Drop-in Tray Single Unit Charger	17
Charging a Stand-alone Battery	18
Charging a Standard Battery	18
Identifying the Drop-In Charger's Position Before Charging Battery	19
Charging a High Capacity Battery	20
Drop-in Tray Charger LED Indicators ..	21
Estimated Charging Time	22

CONTENTS

CONTENTS

Charging a Radio and Battery Using a Multi-Unit Charger-MUC (Optional Accessory)	23	Learning To Read The Values The Radio Signals You	32
Getting Started	24	Reading Frequencies Values	35
Turning radio ON/OFF	24	36
Adjusting volume	24	Reading CTCSS/DPL Values	36
Selecting a Channel	24	Reading Auto-Scan Values	37
Talking and Monitoring	24	Programming Frequencies, Codes and Auto-Scan	37
Receiving a Call	25	Saving Settings	37
Talk Range	25	Programming Mode FAQ	38
Radio LED Indicators	27	Programming values example	39
Hands-Free Use/VOX	29	Example of Programming a Frequency	39
With Compatible VOX Accessories.	29	Scan	41
Hands Free without Accessories (iVOX)30		Editing Scan List	42
Setting VOX Sensitivity	30	Nuisance Channel Delete	42
Microphone Gain	30	CPS (Computer Programming Software) .	43
Battery Save	30	Bandwidth Select	44
Reset To Factory Defaults	31	Time-Out Timer	44
End of Transmission Tone (Roger Beep Tone)	31	Battery Type Setting	44
Programming Features	32	Call Tones	44
Programming Mode	32	Scramble	44
		Cloning Radios	45

CONTENTS

When ordering the MUC	46
What to do if cloning fails	48
Cloning using the CPS (Computer Programming Software)	48
Troubleshooting	49
Use and Care	52
Frequency and Code Charts	53
Motorola Limited Warranty For The United States and Canada	57
What Does this Warranty Cover?	57
Products and Accessories	57
Exclusions	58
Exclusions	59
Export Law Assurances	60
Accessories	61
Audio Accessories	61
Battery	61
Carry Accessories	61
Software Applications	61
Cables	61
Chargers	62

COMPUTER SOFTWARE COPYRIGHTS

The Motorola products described in this manual may include copyrighted Motorola computer programs stored in semiconductor memories or other media. Laws in the United States and other countries preserve for Motorola certain exclusive rights for copyrighted computer programs, including, but not limited to, the exclusive right to copy or reproduce in any form the copyrighted computer program. Accordingly, any copyrighted Motorola computer programs contained in the Motorola products described in this manual may not be copied, reproduced, modified, reverse-engineered, or distributed in any manner without the express written permission of Motorola.

COMPUTER SOFTWARE COPYRIGHTS

Furthermore, the purchase of Motorola products shall not be deemed to grant either directly or by implication, estoppel, or otherwise, any license under the copyrights, patents or patent applications of Motorola, except for the normal non-exclusive license to use that arises by operation of law in the sale of a product.

SAFETY

PRODUCT SAFETY AND RF EXPOSURE COMPLIANCE



Caution

Before using this product, read the operating instructions and RF energy awareness information contained in the Product Safety and RF Exposure booklet enclosed with your radio.

ATTENTION!

This radio is restricted to occupational use only to satisfy FCC RF energy exposure requirements.

For a list of Motorola-approved antennas, batteries, and other accessories, visit the following website which lists approved accessories:

<http://www.motorola.com/XTNi>

SAFETY

BATTERIES AND CHARGERS SAFETY INFORMATION

This document contains important safety and operating instructions. Read these instructions carefully and save them for future reference.

Before using the battery charger, read all the instructions and cautionary markings on

- the charger,
- the battery, and
- the radio using the battery.

1. To reduce risk of injury, charge only the rechargeable Motorola-authorized batteries. Other batteries may explode, causing personal injury and damage.
2. Use of accessories not recommended by Motorola may result in risk of fire, electric shock, or injury.

BATTERIES AND CHARGERS SAFETY INFORMATION

3. To reduce risk of damage to the electric plug and cord, pull by the plug rather than the cord when disconnecting the charger.
4. An extension cord should not be used unless absolutely necessary. Use of an improper extension cord could result in risk of fire and electric shock. If an extension cord must be used, make sure that the cord size is 18AWG for lengths up to 100 feet (30.48 m), and 16AWG for lengths up to 150 feet (45.72 m).
5. To reduce risk of fire, electric shock, or injury, do not operate the charger if it has been broken or damaged in any way. Take it to a qualified Motorola service representative.
6. Do not disassemble the charger; it is not repairable and replacement parts are not available. Disassembly of the charger may result in risk of electrical shock or fire.
7. To reduce risk of electric shock, unplug the charger from the AC outlet before attempting any maintenance or cleaning

OPERATIONAL SAFETY GUIDELINES

- Turn the radio OFF when charging battery.
- The charger is not suitable for outdoor use. Use only in dry locations/conditions.
- Connect charger only to an appropriately fused and wired supply of the correct voltage (as specified on the product).
- Disconnect charger from line voltage by removing main plug.
- The outlet to which this equipment is connected should be nearby and easily accessible.
- In equipment using fuses, replacements must comply with the type and rating specified in the equipment instructions.
- Maximum ambient temperature around the power supply equipment must not exceed 40°C (104°F).
- Power output from the power supply unit must not exceed the ratings stated on the product label located at the bottom of the charger.
- Make sure the cord is located where it will not be stepped on, tripped over, or subjected to water, damage, or stress.

BATTERIES AND CHARGERS SAFETY INFORMATION

RADIO OVERVIEW

PARTS OF THE RADIO

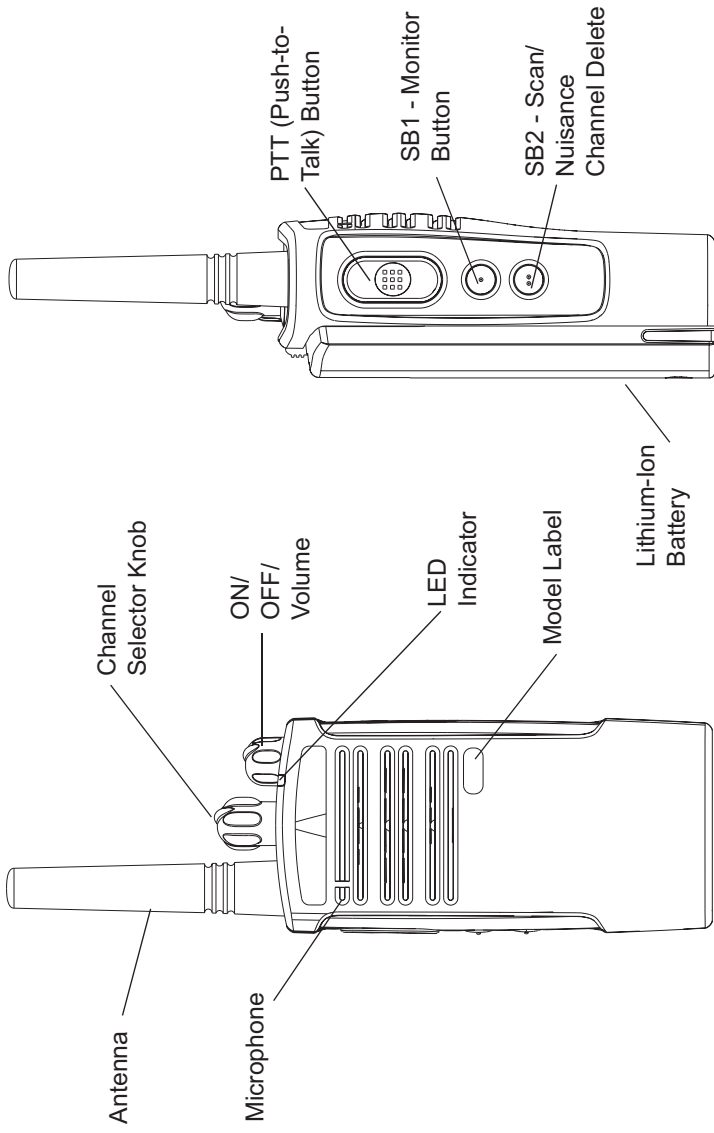

ON/OFF/Volume Knob

Used to turn the radio ON or OFF and to adjust the radio's volume.

Channel Selector Knob

Used to switch the radio to different channels.

Microphone

Speaks clearly into the microphone when sending a message.

Antenna

The radio's antenna is non-removable.

LED Indicator

Used to give battery status, power-up status, radio call information and scan status

Side Buttons

- Push-to-Talk (PTT) Button

Press and hold down this button to talk, release it to listen.

- Side Button 1 (SB1)

The Side Button 1 is a general button that can be configured by the Computer Programming Software - CPS. The default setting of SB1 button is 'Monitor'.

- Side Button 2 (SB2)

The Side Button 2 is a general button that can be configured by the CPS. The SB2 default setting is 'Scan/Nuisance Channel Delete'.

The Lithium-Ion (Li-Ion) Battery

XTNj™ Series provides different types of batteries. For more information, see 'Battery Features and Charging Options' on page 11.

This User Guide covers multiple XTNi™ Series underneath the speaker, and tells you the models, and may detail some features your following information:
radio does not have. The model number of the radio is shown on the front of the radio,

Model	Frequency Band	Transmit Power (Watts)	Number of Channels	Antenna
XTNi	PMR446	0.5	8	Non-removable

BATTERIES AND CHARGERS

XTNi™ Series radios provide Lithium-Ion (Li-Ion) batteries that comes in different capacities that will define the battery life. It also offers the option to use Alkaline batteries. The radio comes equipped with a rapid charger.

BATTERY FEATURES AND CHARGING OPTIONS

About the Li-Ion Battery

The XTNi™ radio series come equipped with a rechargeable Li-Ion battery. This battery should be charged before initial use to ensure optimum capacity and performance.

Battery life is determined by several factors. Among the more critical are the regular overcharge of batteries and the average depth of discharge with each cycle. Typically, the greater the overcharge and the deeper the average discharge, the fewer cycles a battery will last. For example, a battery which is overcharged and discharged 100% several

times a day, lasts fewer cycles than a battery that receives less of an overcharge and is discharged to 50% per day. Further, a battery which receives minimal overcharging and averages only 25% discharge, lasts even longer.

Motorola batteries are designed specifically to be used with a Motorola charger and vice versa. Charging in non-Motorola equipment may lead to battery damage and void the battery warranty. The battery should be at about 77°F (25°C) (room temperature), whenever possible. Charging a cold battery (below 50° F [10°C]) may result in leakage of electrolyte and ultimately in failure of the battery. Charging a hot battery (above 95° F [35°C]) results in reduced discharge capacity, affecting the performance of the radio. Motorola rapid-rate battery chargers contain a temperature-sensing circuit to ensure that batteries are charged within the temperature limits stated above.

Battery Recycling and Disposal

Li-Ion rechargeable batteries can be recycled. However, recycling facilities may not be available in all areas. Under various U.S. state laws and the laws of several other countries, batteries must be recycled and cannot be disposed of in landfills or incinerators. Contact your local waste management agency for specific requirements and information in your area. Motorola fully endorses and encourages the recycling of Li-Ion batteries. In the U.S. and Canada, Motorola participates in the nationwide Rechargeable Battery Recycling Corporation (RBRC) program for Li-Ion battery collection and recycling.

Many retailers and dealers participate in this program. For the location of the drop-off facility closest to you, access RBRC's Internet web site at www.rbrc.com or call 1-800-8-BATTERY. This internet site and telephone number also provides other useful information concerning recycling options for consumers, businesses and governmental agencies.

BATTERIES AND CHARGERS

Installing the Lithium-Ion (Li-Ion) Battery

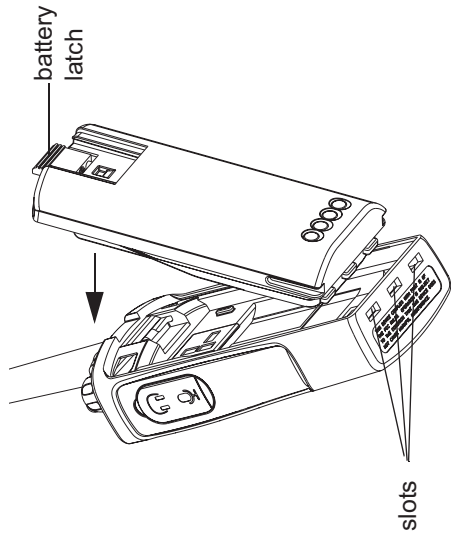

1. Turn OFF the radio.
2. With the Motorola logo side up on the battery pack, fit the tabs at the bottom of the battery into the slots at the bottom of the radio's body.
3. Press the top part of the battery towards the radio until a click is heard.

Note: To learn about the Li-Ion Battery Life features, refer to 'About the Li-Ion Battery' on page 11.

Removing the Lithium-Ion (Li-Ion) Battery

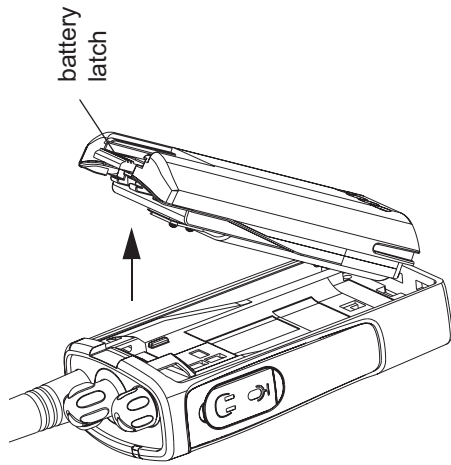

1. Turn OFF the radio.
2. Push down the battery latch and hold it depressed while removing the battery.
3. Pull the battery away from the radio.

Alkaline battery pack (optional accessory) Installing Alkaline Battery Pack

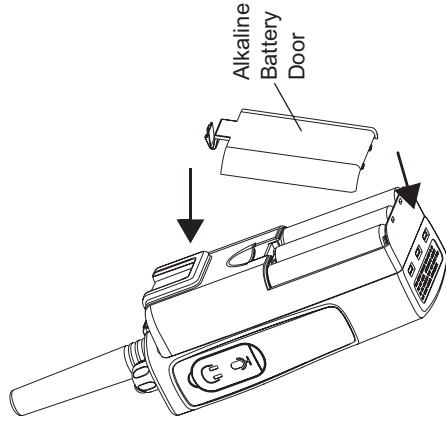

1. Turn OFF the radio, if it is turned on.
2. Remove Li-Ion battery
3. Assemble alkaline battery pack (optional accessory) in the same steps as installing the Li-Ion battery pack.
4. Remove battery door from alkaline battery pack.
5. Slide the 5 AA alkaline batteries into the frame, matching the markings inside the compartment.

Removing Alkaline Batteries

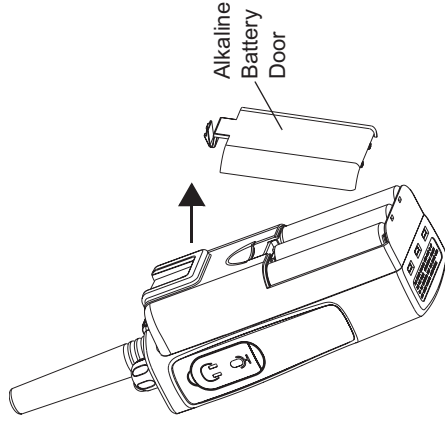

1. Turn OFF the radio, if it is turned on.
2. Slide the battery latches, on both sides of the battery, downwards.
3. Pull the top of the battery away from the radio's body, and lift the battery from the radio's body.

Power Supply, Adaptors and Drop-in Tray Charger

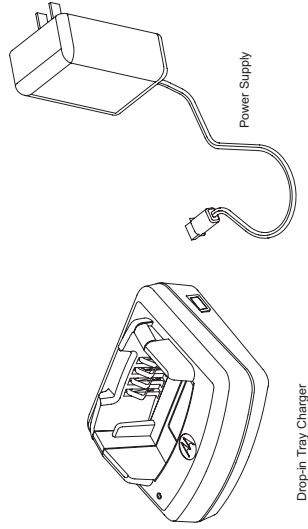

Your radio comes with one Drop-in Tray Charger, one Power Supply (also known as Transformer) and a set of adaptors.

Your power supply, has a 'switchable' capability which allows to suit any of the adaptors that comes with your radio package. The adaptor you should choose to install depends on the region you're located.

Once you have identified the adaptor that matches your electrical outlet, proceed to install it as follows:

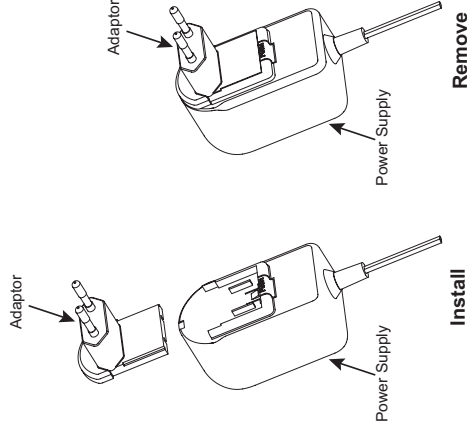

- Slide down the adaptor grooves into the power supply until it snaps into place.
- Slide the adaptor upward to remove.

Note: The adaptor shown in the pictures are just for illustration purposes. The adaptor you should install may be different.

Installing Spring Action Belt Clip

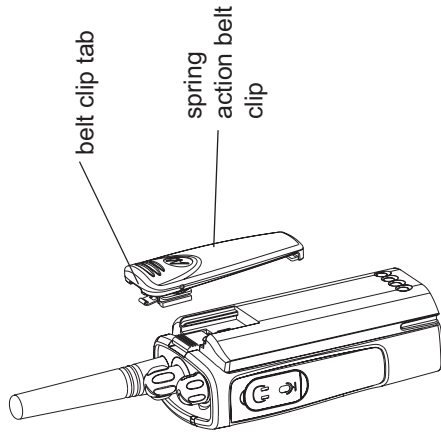

1. Slide the spring action belt clip rails into the belt clip grooves on the back of the battery pack and slide it down until the belt clip tab snaps into place.
2. To remove, pull back the metal release tab on the belt clip tab and push the spring action belt clip upward to remove.

Battery Life Information

Li-Ion Battery Life

Depending on the radio model and/or region the battery capacity will be different. This feature will determine the estimated battery life. When the Battery Save feature is ON (enabled by default) the battery life will be longer. The following chart summarizes battery life estimations:

Li-Ion Battery Life with Battery Save feature ON	
Battery	0.5 Watt
Standard	16 hours
High Capacity	32 hours

Note: Battery life is estimated based on 5% transmit/ 5% receive/ 90% standby standard duty cycle.

Alkaline Battery Life

The following chart provides estimations about the Battery Life using the Alkaline Batteries:

Alkaline Battery Life	
Battery Save Feature	0.5 Watt
ON	37 hours

Note: Battery life are being estimated based on 5% transmit/ 5% receive/ 90% standby standard duty cycle.

Charging the Battery

To charge the battery (with the radio attached), place it in a Motorola-approved Drop-in Tray Single Unit Charger or Drop-in Tray Multi-Unit Charger.

Charging with the Drop-in Tray Single Unit Charger

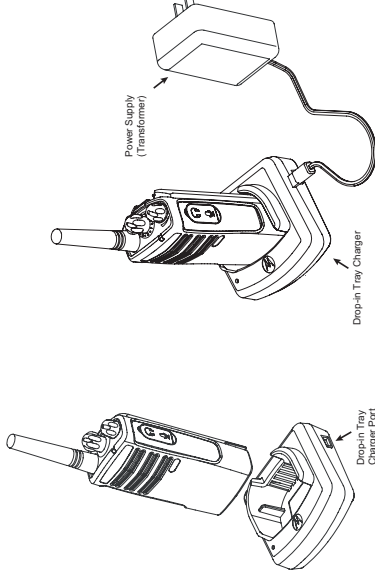

1. Place the drop-in tray charger on a flat surface.
2. Insert the connector of the power supply into the port on the side of the drop-in tray charger.
3. Plug the AC adaptor into a power outlet.
4. Insert the radio into the tray with the front of the

radio facing the front of the charger, as shown.

Note: When charging a battery attached to a radio, turn the radio OFF to ensure a full charge. See 'Operational Safety Guidelines' on page 7 for more information.

Important: Ensure that the bracket in the charger is adjusted to the correct position for either Standard or High-capacity battery. See 'Charging a Standard Battery' on page 18.

Charging a Stand-alone Battery

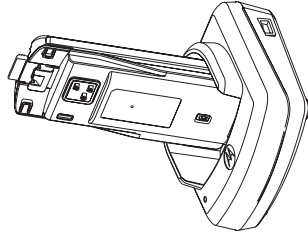

Charging a Standard Battery

The drop-in tray charger has a removable bracket that is adjustable depending on the type of battery that needs to be charged. It is designed to charge either the battery (with the radio) or a stand-alone battery. The drop-in tray charger comes by default set up to charge a standard battery. The following image on page 19 shows the orientation for each battery:

To charge a battery whilst not attached to the radio - at step 4 above, insert the battery into the tray, with the inside surface of the battery facing the front of the charger, as shown. Ensure the slots in the battery correctly engage in the charger.

Identifying the Drop-In Charger's Position Before Charging Battery

BATTERIES AND CHARGERS

Adjustable bracket

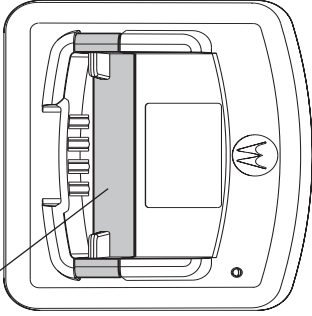

Standard

Adjustable bracket

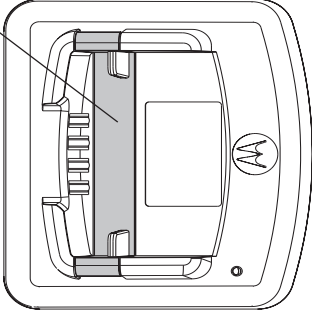

High and Ultra High Capacity

Charging a High Capacity Battery

BATTERIES AND CHARGERS

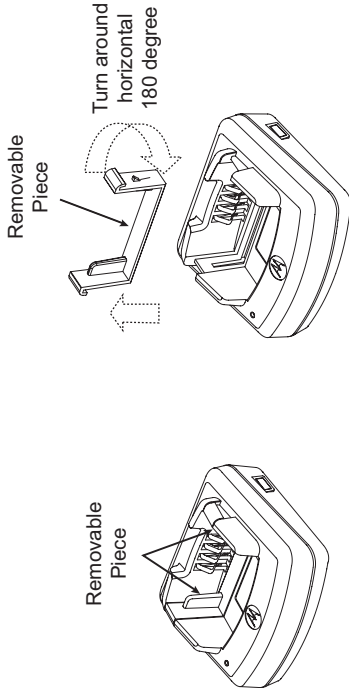

To convert the charger from the default setup to accommodate the high capacity:

1. Squeeze both tabs on each side of the removable bracket in the drop-in charger tray carefully and lift the bracket from the charger tray.
2. Rotate the removable bracket 180 degrees and replace it by fitting it in the charger slot until it clicks. The label on the removable bracket should show 'High & Ultra Capacity Battery' facing front of the charger.

3. Repeat same procedure to return position back to charging a Standard Battery. Label on the removable bracket should show 'Standard Battery' facing front.

Note: Make sure the bracket is assembled correctly for both standalone battery and battery (with radio) to be properly charged.

Drop-in Tray Charger LED Indicators

Standard Charger LED Indicator		
Status	LED Status	Comments
Power ON	Steady red indication for 3 seconds	The charger has powered up
Charging	Blinking red (slow)	The charger is currently charging
Charging Complete	Steady red indication	Battery is fully charged
Battery Fault(*)	Blinking red (fast)	Battery had a fault when battery was inserted

Notes:

- (*) Normally re-seating the battery pack will correct this issue.
- (**) Battery temperature is too warm or too cold or wrong power supply is being used

Rapid Charger LED Indicator		
Status	LED Status	Comments
Power ON	Steady green indication for 3 seconds	The charger has powered up
Charging	Blinking green	The charger is currently charging
Top-off Charging	Blinking green (slow)	Battery is near fully charged
Charge Complete	Steady green indication	Battery is fully charged
Battery Fault (*)	Blinking red (fast)	Battery has a fault when battery was inserted
Waiting to Charge (**)	Double-blink yellow indications	Battery charging conditions not suitable

Notes:

- (*) Normally re-seating the battery pack will correct this issue.
- (**) Battery temperature is too warm or too cold or wrong power supply is being used

Estimated Charging Time

The following table gives the estimated times to charge the battery. For further details, see ‘Accessories’ on page 58.

Estimated Charging Time		
Charging Solution	Battery Capacity	
	Standard	High
Rapid Charging Solution	1.5 hours	3 hours

Charging a Radio and Battery Using a Multi-Unit Charger-MUC (Optional Accessory)

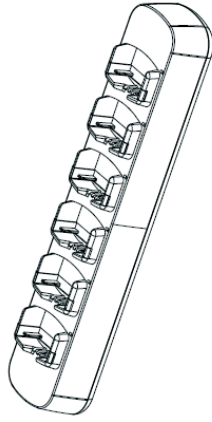

The Multi-Unit Charger (MUC) allows drop-in charging of up to 6 radios or batteries. Batteries can be charged with the radios or removed and placed in the MUC separately. Each of the 6 charging pockets can hold a radio or battery, but not both.

1. Place the charger on a flat surface.
2. Insert the power cord plug into the jack on the MUC.
3. Plug the cord into an AC outlet.
4. Turn the radio OFF.
5. Set removable bracket for battery type.

6. Insert the radio or battery into the charging pocket.

Notes:

- This Multi-Unit Charger will also allow you to clone up to 3 radios (3 Source radios and 3 Target radios).
- When cloning, the MUC does not need to be plugged into a power source, but all radios require charged batteries. Further details on MUC's operation are explained in the Instructions Sheet provided with the MUC. Refer to the "Accessories" section to identify the part number for ordering the MUC.

BATTERIES AND CHARGERS

MUC LED Indicator		
Status	LED Status	Comments
Charging	Steady Red Indication	The charger is currently charging
Charge Complete	Steady Green Indication	Battery is fully charged
Battery Fault (*)	Red Fast blinking	Battery had a fault when battery was inserted

(*) Normally re-seating the battery pack will correct this issue.

GETTING STARTED

For the following explanations, refer to page 8 of the user guide.

TURNING RADIO ON/OFF

To turn ON the radio, rotate the ON/OFF/Volume Knob clockwise. The radio will chirp and the LED will briefly blink red.

To turn the radio OFF, rotate the ON/OFF/Volume Knob counterclockwise until you hear a 'click' and the radio LED indicator turns OFF.

ADJUSTING VOLUME

Turn the ON/OFF/Volume Knob clockwise to increase the volume, or counterclockwise to decrease the volume.

Note: Do not hold the radio too close to the ear when it is at a high volume setting or when adjusting the volume setting.

SELECTING A CHANNEL

To select a channel, rotate the Channel Selector Knob and select the desired channel number.

Program each channel separately. Each channel has its own Frequency, Interference Eliminator Code and Scan Settings.

TALKING AND MONITORING

It is important to monitor for traffic before transmitting to avoid 'talking over' someone who is already transmitting

To monitor, press and hold the SB1(*) button for 2 to 3 seconds to access channel traffic. If no activity is present, you will hear 'static'. To release, press SB1 again. Once channel traffic has cleared, proceed with your call by pressing the PTT button. When transmitting, the radio LED will blink red every 3 seconds.

(*) This assumes SB1 has not been programmed for a different mode.

GETTING STARTED

RECEIVING A CALL

1. Select a channel by rotating the Channel Selector Knob until you reach the desired channel.
2. Make sure the PTT button is released and listen for voice activity.
3. The LED indicator blinks RED while the radio is receiving a call.
4. To respond, hold the radio vertically 1 to 2 inches (2.5 to 5cm) from mouth. Press the PTT button to talk; release it to listen.

Note: Please notice that when radio is receiving or transmitting, LED is always RED.

Note: In order to listen to all activity on a current channel, short press the SB1 to set the CTCSS/DPL code to 0. This feature is called CTCSS/DPL Defeat (Squeich set to SILENT).

TALK RANGE

XTNi radios have been designed to maximize performance and improve transmission range in the field. It is recommended that you do not use the radios closer than 1.5 meters apart, to avoid interference.

Talk range depends on the terrain. It will be affected by concrete structures, heavy foliage and by operating radios indoors or in vehicles.

Optimal range occurs in flat, open areas with up to 9 kilometres of coverage. Medium range occurs when buildings and trees are in the way. Minimal range occurs when dense foliage and mountains obstruct the communication path.

To establish a proper two-way communication, the channel, frequency, and interference eliminator codes must be the same on both radios. This depends on the stored profile that has been preprogrammed on the radio:

1. Channel: Current channel that the radio is using, depending upon radio model.

2. Frequency: The frequency the radio uses to transmit/receive.

3. Interference Eliminator Code: These codes help minimize interference by providing a choice of code combinations.

4. Scramble Code: Codes that make the transmissions sound garbled to anyone listening who is not set to that specific code.

5. Bandwidth: Some frequencies have selectable channel spacing, which must match other radios for optimum audio quality.

For details of how to set up frequencies and CTCSS/DPL codes in the channels, refer to “Programming Mode” on page 31.

Note: Interference Eliminator Codes are referred also as CTCSS/DPL codes or PL/DPL codes



RADIO LED INDICATORS

RADIO STATUS	LED INDICATION
Channel Alias Edit	Red heartbeat
Channel Busy	Solid orange
Cloning Mode	Two orange heartbeats
Cloning In Progress	Solid orange
Fatal Error at Power up	One green blink, one orange blink, one green blink, then repeat for 4 seconds
Low Battery	Orange blink
Low Battery Shutdown	Orange heartbeat
Monitor	LED is OFF
Power-Up	Solid red for 2 seconds
'Idle' Programming Mode / Channel Mode	Green heartbeat
Scan Mode	Red heartbeat)
Transmit (Tx)/Receive (RX)	Red heartbeat
Transmit Low in Power Select	Orange heartbeat

Note: Channel Alias Edit only applies to Display Models

HANDS-FREE USE/VOX

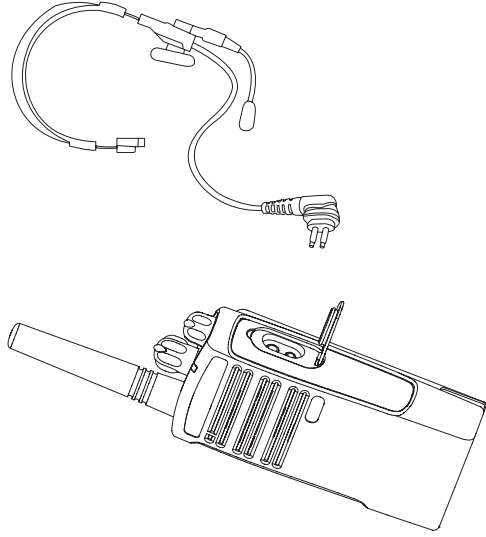

GETTING STARTED

Motorola XTNIJ™ radios can operate hands-free (VOX) when used with compatible VOX accessories. A short delay occurs between talking and the radio transmission.

With Compatible VOX Accessories

The default factory setting for VOX sensitivity level is OFF (level '0'). Before using VOX,

use the CPS (Computer Programming Software) to make sure the VOX level is set to a level different from "0". Then, perform the following steps:

1. Turn radio OFF.
2. Open accessory cover.
3. Insert plug of audio accessory firmly into accessory port.
4. Turn radio ON. Radio LED will blink double red
5. Lower radio volume BEFORE placing accessory near ear.
6. To transmit, speak into accessory microphone and to receive, stop talking.
7. VOX can be temporarily disabled by pressing the PTT button or by removing the audio accessory.

Note: To order accessories, contact your Motorola dealer.

Hands Free without Accessories (iVOX)

- Enable iVOX by pressing the PTT button while turning the radio ON.
- iVOX operation can be temporarily disabled by pressing PTT.
- A short press of the PTT button will re-enable iVOX.

There is a short delay between when talking and the radio transmission.

Note: The iVOX feature is only available on XTNIId (Display model).

Setting VOX Sensitivity

The sensitivity of the radio's accessory or microphone can be adjusted during VOX operation to suit different operating environments. VOX/iVOX sensitivity can be programmed via the CPS.

Default value is OFF (level 0). If you want to use the VOX feature, VOX level should be set at a level different from 0.

- 1 = Low sensitivity
- 2 = Medium sensitivity
- 3 = High sensitivity

Microphone Gain

The sensitivity of the radio's microphone can be adjusted to fit different users or operating environments.

This feature can be adjusted only through the CPS. Microphone default setting is set to level 2 (Medium gain).

Battery Save

Battery Save feature extends battery life as your radio goes into 'Idle' state each time there is no radio activity. To enable/disable press SB1 and SB2 buttons simultaneously for 2 or 3

seconds while powering up the radio until you hear a quick series of beeps. To have a slightly better attack time, set Battery Save feature to OFF so that the radio is always ready to transmit or receive without any delays.

Note: Battery Save feature is set to ON by default

Reset To Factory Defaults

Reset To Factory Defaults will set back all radio features to the original factory default settings. To do so press PTT, SB2 and SB1 simultaneously while turning ON the radio until you hear a high tone chirp beep.

End of Transmission Tone (Roger Beep Tone)

Short press the SB1 button while turning ON the radio to enable/disable End of Transmission Tone.

Note: By default, this feature is OFF.



PROGRAMMING FEATURES

To easily program all the features in your radio, it is recommended to use the CPS Kit which includes the Programming Cable, CPS and accessories sections.

Programming Mode

Programming Mode is special radio mode that allows you to program basic radio's features by using the radio's panel programming.

When the radio is set to Programming Mode, you are able to read and modify three features:

- Frequencies,
- Codes (CTCSS/DPL) and,
- Auto-scan.

The Programming Frequencies feature allows you to select frequencies for each channel.

The Interference Eliminator Code (CTCSS/DPL) helps minimize interference by providing you with a choice of code combinations that

filter out static, noise, and unwanted messages.

The Auto Scan feature allows you to set a particular channel to automatically enable scan each time you switch to that channel (you will not need to press any button to start scanning).

Learning To Read The Values The Radio Signals You

As the non-display model does not have a display to show the values that are being programmed, the radio will communicate this information using beeps and LED indications. The radio's LEDs will blink two colors: 'orange' to signal '0' and red for other values from '1' to '9'. Short and long red blinks differentiate the specific number the radio is showing you.

As the radio blinks the number, it will generate a combination of short and long beeps.

PROGRAMMING FEATURES

Table 1: Programming Mode: Reading your Radio's Features Values

Number	Confirmation Beep	LED Indication
0	Zero beep	One short orange blink
1	One beep	One short red blink
2	Two beeps	Two short red blinks
3	Three beeps	Three short red blinks
4	Four beeps	Four short red blinks
5	Long beep	One long red blink
6	Long beep and one beep	One long and one short red blinks
7	Long beep and two beeps	One long and two short red blinks
8	Long beep and three beeps	One long and three short red blinks
9	Long beep and four beeps	One long and four short red blinks

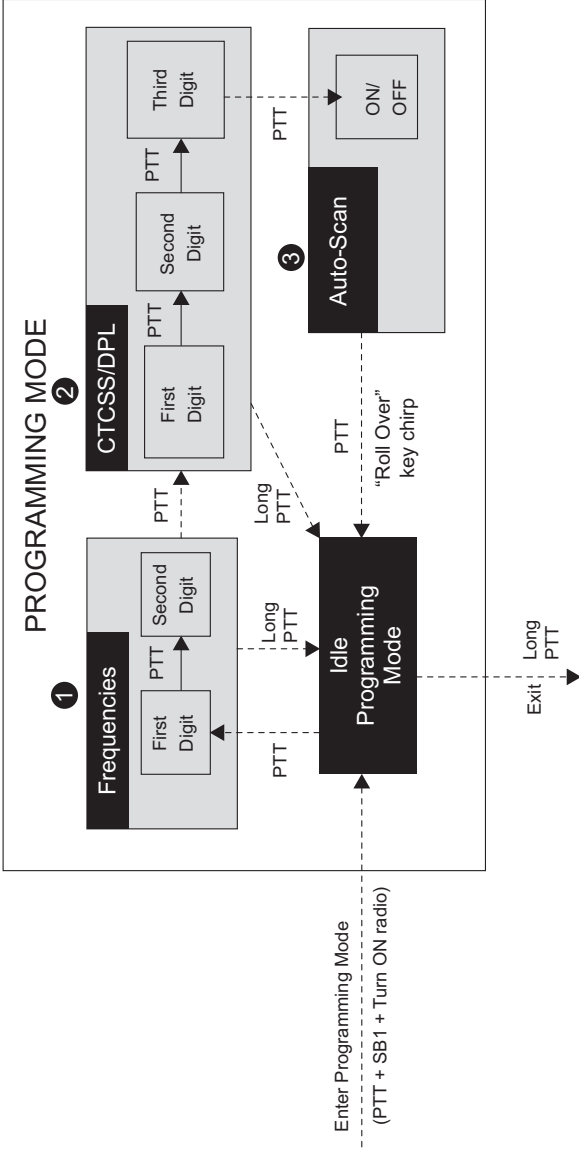

Figure 1 Entering Programming Mode

Entering Programming Mode

Note: Before programming the features, make sure your radio is set to the channel you wish to program. You can do so before entering Programming Mode or at any time during the Programming Mode by turning the Channel Selector Knob to the desired channel.

To read or modify frequencies, codes and auto-scan, set the radio to 'Programming Mode' by long pressing both the PTT and the SB1 button simultaneously while turning ON the radio for 3 to 5 seconds until a 'chirp' sounds to indicate that you have entered 'Idle' Programming Mode (*). The radio LED will start blinking a green heartbeat.

Note: (*) 'Idle' Programming Mode is the stage of the Programming Mode in which the radio is waiting for the user to start the radio programming cycle (refer to the Programming Mode picture above).

Once you are in the 'Idle' Programming Mode, you will be able to read the radio frequencies, codes and auto-scan setting by short pressing the PTT button to move along the different programmable features.

Reading Frequencies Values

When reading frequencies values you need to read two digits as XTNj™ series radios have 16(*) frequencies for UHF (refer to UHF Frequencies tables).

Once in 'Idle' Programming Mode, the radio will signal the first value it was programmed when you short press the PTT button (see picture below). This value corresponds to the frequency's first digit value. If you short press the PTT button again, the radio will signal you the second digit value.

The following is an example of the order in which your radio will be signaling the '118' CTCSS/DPL code:

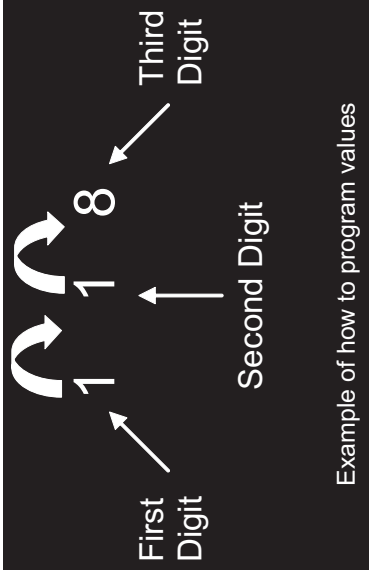

- Short press the PTT button. The radio will signal you the first digit '1', short press PTT button again and the radio will show the second digit '1' and finally, short press PTT again and radio will show the third digit '8'.

1

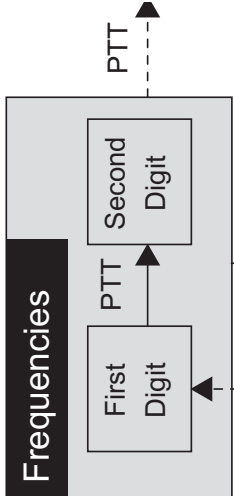

Reading CTCSS/DPL Values

If you continue short pressing the PTT button, as shown in the "Entering Programming Mode" on page 33 (Stage 2) the radio will move forward to programming CTCSS/PL Codes.

When reading the values for CTCSS/PL Codes the radio signals you the digit codes each time you short press the PTT button. You will have to read three digits as XTNi Series™ have up to 122 codes available (refer to 'Frequencies and Codes Charts' Section).

Reading Auto-Scan Values

After finishing reading CTCSS/DPL codes, if you short press PTT once again, the radio will take you to Auto-Scan ("Entering Programming Mode" on page 33 (stage 3) Auto-Scan only has two values:

<i>If the radio signals the value...</i>	<i>It means Auto-Scan is....</i>
0	OFF
1	ON

Note: AutoScan is set to OFF by default.

Note that while in Auto-Scan Mode, if you short press PTT button, the radio will return to the 'Idle' Programming Mode. It will then generate a 'roll-over' chirp and it will start blinking a green heartbeat.

Programming Frequencies, Codes and Auto-Scan

Each time your radio signals and beeps, you can change the current setting value by either increasing it by short pressing SB1 or decreasing it by short pressing SB2. The radio will then signal the new setting it has been programmed to.

Saving Settings

If you are satisfied with the new setting, you can either:

- short press PTT to continue programming,
- long press PTT to save and return to 'Idle' Programming Mode, or
- long press the PTT button twice to exit 'Idle' Programming Mode and return to the normal radio operation.

Notes:

- If you don't want to save the value you just programmed, turn radio OFF or change channel using the channel knob.
- If you 'roll-over' to the beginning at Idle Programming Mode you will hear a 'chirp' and radio LED will start blinking green again. All values that were changed will be automatically saved.

Programming Mode FAQ

1. I got distracted while programming and forgot which digit I was programming. What should I do?

Return to 'Idle' Programming Mode and start over, as you will not be able to go back into the Programming Mode (the radio does not provide further way to let you know the specific stage you are when programming). Therefore you can:

- Long press the PTT button. The radio will return to the 'Idle' Programming Mode or,

- Turn OFF the radio and enter Programming Mode again (see instructions in the beginning of this section)

2. I am trying to program a frequency (or code) value but the radio would not do it. It rolled over and took me back to value '0'.

The radio will not allow you to program any values that are not available in the frequencies and codes pool. For example, if you try to program code 128, the radio would not accept it, as the maximum value allowed is 122. Same thing will happen with frequencies. Check the Frequencies and Codes Charts section to make sure you are programming a valid number.

3. I am trying to enter the Programming Mode but the radio would not do it.

The radio might be locked using the CPS for not allowing Front-Panel Programming. To reenable, use the CPS.

4. When I was programming I made a mistake and program the wrong value. How can I erase it or re-program it?

If you make a mistake while programming a value you have two choices:

- a) The radio roll-over (and generates a 'wrap-around' sound) each time it reaches a maximum (9) or minimum (0) value. Keep increasing (short press SB1) or decreasing (short pressing SB2) until you get the desired value or,
- b) Turn OFF the radio and start-over.

5. I just programmed the value I wanted. How do I exit Programming Mode?

- If you are in Programming Mode you can exit by long pressing the PTT button twice.
- If you are already in the 'Idle' Programming Mode, long press the PTT button once.

6. I am done programming the features in this channel and want to program another channel.

Switch to the new channel you wish to program by using the Channel Selector Knob. The radio will go into the 'Idle' Programming Mode. If you wish to save the changes, make sure you are in the 'Idle' Programming Mode before switching the channel as otherwise you will lose changes made.

PROGRAMMING VALUES EXAMPLE

Example of Programming a Frequency

Assuming current frequency value is set up to channel 1, with the UHF default frequency '02' (equivalent to 446.01875 Mhz), and you want to change it to Frequency Number = '13' (which is mapped to 446.05625 Mhz), follow this sequence:

- Enter Programming Mode

- Short press the PTT button to enter Frequency Mode. Radio will signal current value '0' (orange blink)
- Press the SB1 button once to increase first digit to '1'.
- Short press the PTT button once to move ahead and program the frequency's second digit. Radio will signal current value which is '2' (two red blinks).
- Press the SB1 button to increase the digit value to '3'.
- Long press the PTT button. LED indicator will show a green heartbeat to indicate 'Idle' state.
- Long press the PTT button to exit Programming Mode or turn radio OFF.

Example of Programming a Code

Assuming current code value is set to factory default '001', and you want to change it to CTCSS/DPL Code = 103 follow the sequence below:

- Enter Programming Mode

- Short press the PTT button three times (Enter CTCSS/DPL Programming Selection Mode). Radio LED will blink orange to indicate that current value is '0' • Press the SB1 button once (to change first digit to '1') LED indicator will blink red. Short press the PTT button (to move forward and program second digit). Radio LED will blink orange to indicate current value is '0'.
- Short press the PTT button and move ahead to program the third digit. LED indicator will blink red to indicate current value is '1'.
- Press the SB1 button to change the 'third digit' to '2'. Press the SB1 button to change again this 'third digit' to '3'. Radio will signal the chosen value.
- Long press the PTT button to save changes and return to 'Idle' Programming Mode.
- Once in 'Idle' Programming Mode, LED indicator will start blinking a green heartbeat.
- Long press the PTT button to exit Programming Mode.

Example of Programming Auto Scan

Auto-Scan is the last Programming Mode and can be set to "ON" or "OFF" on a particular channel. To set Auto Scan to "ON":

1. Enter Programming Mode and select the desired channel (see "Entering Programming Mode" picture in page 38).
2. Short press the PTT button six times to enter Auto Scan Programming Selection Mode. The radio will signal beeps and will show the current

Auto Scan setting (please refer to "Reading Auto-scan Settings" in page 41).

3. Short press the SB1 button to toggle ON/OFF the auto-scan feature in the channel. When ON radio LED will blink RED once. When OFF radio LED will blink ORANGE once.

OTHER PROGRAMMING FEATURES

SCAN

Scan allows you to monitor other channels in order to detect conversations.

When the radio detects a transmission, it will stop scanning and will stay on the active channel. This will allow you to listen and talk to the people on that stopped channel without having to change the channel knob. If there is talking going on channel 2 during this time, the radio will stay on channel 1 and you will not hear channel 2. After talking has stopped in channel 1, the radio will wait 5 seconds before resuming scan again.

- To start scanning, press the SB2 button (*). When the radio detects channel activity, it will stop on that channel until the activity ends. You can talk to the person(s) transmitting without having to switch channels by pressing PTT.
- To stop scanning, short press the SB2 button again.
- By pressing the PTT button while the radio is

scanning, the radio will transmit on the channel which was selected before Scan was activated.

If no transmission occurs within five seconds, scanning will resume.

- If you want to scan a channel without Interference Eliminator Codes (CTCSS/DPL), set the code settings for the channels to '0' in the CTCSS/DPL Programming Selection Mode.

Whenever the radio is set up in Scan, the LED will signal a red blink.

Note: (*)Assumes the SB2 button is not programmed to other function different from the default. If Auto-Scan has been enabled for a particular channel, do not press SB2 to scan the channel, as the radio will do it automatically.

Editing Scan List

Scan Lists can be edited by using the CPS

(refer to "CPS (Computer Programming Software)" on page 42.

Nuisance Channel Delete

Nuisance Channel Delete allows you to temporarily remove channels from the Scan List. This feature is useful when irrelevant conversations on a 'nuisance' channel tie up the radio's scanning feature. To delete a channel from the scan list:

- Start Scanning by short pressing the SB2 button(*)
- Wait until the radio stops on the channel you wish to eliminate, then long press the SB2 button to delete it.
- The channel will not be removed until you exit Scan by short pressing the SB2 button again or by turning the radio OFF.

Note: (*) Assumes the SB2 button is not programmed to another function different from the default.

CPS (COMPUTER PROGRAMMING SOFTWARE)

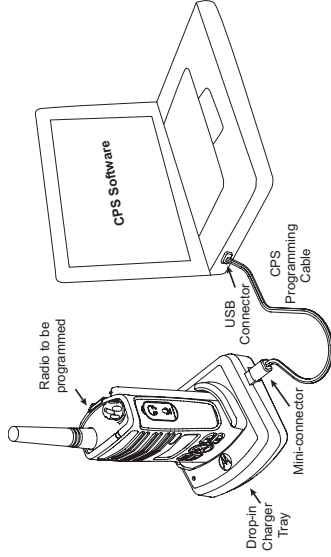

features such as: Direct Frequency Input, Repeater/Talkaround, Bandwidth Select, Time-out Timer, Power Select, Battery Type Select, Scan List, Call Tones, Scramble, Reverse Burst etc. CPS is a very useful tool as it can also lock the frontpanel radio programming or restrict any specific radio feature to be changed (to avoid preset radio values to be accidentally erased).

It also provides security by giving the option to set up a password for profile radio's management. Please refer to Features Summary Chart Section at the end of the User's Guide for more details.

Note: • Features should be enabled by an Authorized Motorola Dealer. Contact your Motorola Point of Purchase for details

Note: (*) CPS Programming Cable is an accessory sold separately. For part number information refer to the Accessories Section.

The easiest way to program or change features in your radio is by using the Computer Programming Software (CPS) and the CPS Programming Cable(*). CPS Software is available for free as web based downloadable software at www.motorola.com/XTNi.

To do so, connect the XTNi radio via the Drop-in Charger Tray and CPS Programming Cable as shown in the picture above.

The CPS allows the user to program frequencies, PL/DPL codes, as well as other

Bandwidth Select

Default setting for Bandwidth Select is 12.5 KHz. Some frequencies have selectable channel spacing, which must match other radios for optimum audio quality.

Time-Out Timer

When pressing PTT buttons, transmissions can be terminated by setting up a Time-Out Timer. The radio can be programmed to turn the radio 'OFF' in either 60, 120 or 180 seconds.

Battery Type Setting

The XTNI™ radio can be powered by either Alkaline or Lithium-Ion batteries.

Call Tones

Call Tones enable you to transmit to other radios in your group by alerting them that you are about to talk or alerting them without speaking.

Scramble

The Scramble feature makes transmissions sound garbled to anyone listening without the same code. Scramble default value is OFF.

Note: Some of the features available with the CPS software may vary depending on the radio model.

Reverse Burst

Reverse Burst eliminates unwanted noise (squelch tail) during loss of carrier detection. Can select values 180/240.

Notes:

- The features described in previous pages are just some of the features CPS has. CPS offers more capabilities. For more information please refer to the HELP file in the CPS.
- Some of the features available with the CPS software may vary depending on the radio model.

CLONING RADIOS

You can copy XTNj™ Series radio profiles from one Source radio to a Target radio by using any of these 3 methods:

1. One Multi Unit Charger (optional accessory)
2. Two single unit chargers and a Radio-to-Radio cloning cable (optional accessory)
3. the CPS (free software download)

Cloning with a Multi-Unit Charger (MUC)

To clone radios using the MUC, there must be at least two radios:

- a Source radio(radio to be cloned or copied) and
- a Target radio (radio which profile will be changed to be the same as the source radio.)

The Source radio has to be in Pocket 1, 3 or 5 while the Target radio to be cloned has to be in Pockets 2, 4 or 6, matching the MUC's pockets

by pairs as follows: 1 and 2 or 3 and 4 or 5 and 6.

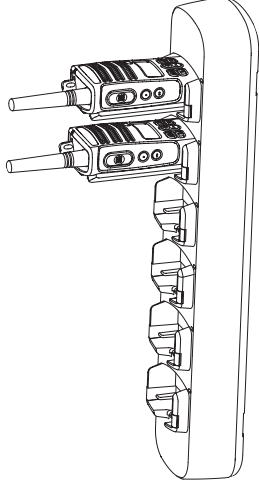

When cloning, the MUC does not need to be plugged into a power source, but ALL radios require charged batteries.

Follow these steps for cloning:

1. Turn ON the Target radio and place it into one of the MUC Target Pockets
2. Power the Source radio following the sequence below:
 - Long press the PTT button and SB2 simultaneously while turning the radio ON.
 - Wait for 3 seconds before releasing the buttons until a distinctive audible tone is heard.
3. Place the Source radio in the source pocket that pairs with the target pocket you chose in step 1.

Press and release SB1.

4. After cloning is completed, the Source radio will sound either a 'pass' tone (cloning was successful) or a 'fail' tone (cloning process has failed). The 'pass' tone sounds like a good key 'chirp' whereas the 'fail' tone sounds similar to a 'bonk' tone. If the Source radio is a display model, it will either show 'Pass' or 'Fail' on the display (a tone will be heard within 5 seconds).

5. Once you have completed the cloning process, turn the radios OFF and ON to exit the 'cloning' mode.

If cloning fails please refer to "What to do if cloning fails" on page 47.

Further details on how to clone units are explained in the instructions sheet provided with the MUC.

When ordering the MUC

See "Chargers" on page 59 for the MUC part number.

Note: (*) MUC pockets numbers should be read from left to right with the Motorola logo facing front.



WARNING

Paired Target radios and Source Radios must be of the same type in order for the cloning to run successfully.

Cloning Radio using the Radio to Radio (R2R) Cloning Cable (optional accessory)

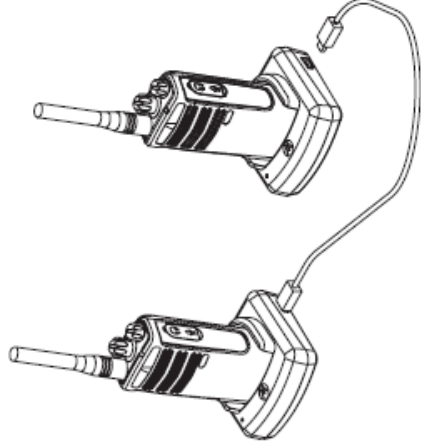

Operating Instructions

1. Before beginning the cloning process, make sure you have:
 - A fully charged battery on each one of the radios.
 - Two Single Unit Chargers (SUC).
 - Turned OFF the radios and,
 - Both radios are of the same radio model.
2. Unplug any cables (power supply or USB cables) from the SUCs.
3. Plug one side of the cloning cable mini connector to one SUC. Plug the other end to the second SUC.

Note: During the cloning process no power is being applied to the SUC. The batteries will not be charged. A data communication is being established between the two radios.

4. Turn ON the Target radio and place it into one of the SUCs.
5. On the Source radio, power the radio following the sequence below:

- Long press the PTT button and SB2 simultaneously while turning the radio ON.
 - Wait for 3 seconds before releasing the buttons until a distinctive audible tone is heard.
6. Place the Source radio” in its SUC, press and release SB1.
 7. After cloning is completed, the Source radio will sound either a “pass” tone (cloning was successful) or a “fail” tone (cloning process has failed). The ‘pass’ tone sounds like a good key ‘chirp’ whereas the ‘fail’ tone sounds similar to a ‘bonk’ tone. If the Source radio is a display model it will either show ‘Pass’ or ‘Fail’ on the display (a tone will be heard in no more than 5 seconds).
 8. Once you have completed the cloning process, turn the radios OFF and ON in order to exit ‘clone’ mode.

What to do if cloning fails

The radio will emit an audible 'bonk' indicating that the cloning process has failed. In the event that cloning fails, try performing each of the following before trying to start the cloning process again:

1. Ensure that the batteries on both radios are fully charged.
2. Check the cloning cable connection on both SUCs.
3. Ensure that the battery is engaged properly on to the radio.
4. Ensure that there is no debris in the charging tray or on the radio contacts.
5. Ensure that the Source radio is in cloning mode.
6. Ensure that the Target radio is turned ON.
7. Ensure both radios are both from the same type. (same frequency band, same front panel (display/hon display), same region and same transmission power).

Attention: This cloning cable is designed to operate only with compatible Motorola RLN6170 (Rapid) Single Unit Charger.

When ordering Cloning Cable please refer to P/N RLN6303. For details about accessories refer to Accessories section.

Cloning using the CPS (Computer Programming Software)

When cloning using this method, you will need to have the CPS software, a Drop-in Tray Charger and the CPS Programming Cable. Information on how to clone using the CPS is available either in the CPS Help File ---> Content and Index --> Cloning Radios or in the CPS Programming Cable Accessory Leaflet.

Note: (*) CPS Programming Cable is an accessory sold separately. For part number information refer to the Accessories Section.

Symptom	Try This
No Power	Recharge or replace the Li-Ion battery. Replace AA batteries. Extreme operating temperatures affect battery life. Refer to "About the Li-Ion Battery" on page 11'.
Hearing other noises or conversation on a channel	Confirm Interference Eliminator Code is set. Frequency or Interference Eliminator Code may be in use. Change settings; either change frequencies or codes on all radios. Make sure radio is at the right frequency and code when transmitting. Refer to "'Talking and Monitoring" on page 24
Message Scrambled	Scramble Code might be ON, and/or setting does not match other radios' settings.
Limited talk range	Steel and/or concrete structures, heavy foliage, buildings or vehicles decrease range. Check for clear line of sight to improve transmission. Wearing radio close to body such as in a pocket or on a belt decreases range. Change location of radio. Refer to "Talking and Monitoring" on page 24.

Symptom

Try This

TROUBLESHOOTING

<p>Message not transmitted/received</p>	<p>Make sure the PTT button is completely pressed if you're transmitting. Confirm radios have the same Channel, Frequency, Interference Eliminator Code and Scramble Code settings. Refer to the 'Talking and Monitoring' Section on page 24 for further information.</p> <p>Recharge, replace and/or reposition batteries. Refer to 'About your Li-Ion Battery' section on page 11.</p> <p>Obstructions and operating indoors, or in vehicles, may interfere: change location. Refer to 'Talking and Monitoring' Section on page 24.</p> <p>Verify that the radio is not in Scan Mode. Refer to the "Scan" on page 40 "CPS (Computer Programming Software)" on page 42 and "Nuisance Channel Delete" on page 41.</p>
<p>Heavy static or interference</p>	<p>Radios are too close, they must be at least five feet apart. Radios are too far apart or obstacles are interfering with transmission. Refer to the 'Talking and Monitoring' Section on page 24.</p>
<p>Low batteries</p>	<p>Recharge or replace Li-Ion battery. Replace AA batteries. Extreme operating temperatures affect battery life. Refer to 'About the Li-Ion Battery' Section on page 11.</p>

Try This

Symptom

<p>Drop-in Charger LED light does not come on</p>	<p>Check radio/battery is properly inserted and check battery/charger contacts to be sure they are clean and charging pin is inserted correctly. Refer to 'Charging the Battery' section on page 17, 'Drop-in Tray Charger LED Indicators' section on page 21 and 'Installing the Lithium-Ion Battery' section on page 13.</p>
<p>Low battery indicator is blinking although new batteries are installed</p>	<p>Verify that the radio is set to the correct battery type. Refer to the 'Installing the Li-Ion Battery' section on page 13, "Installing Alkaline Battery Pack" on page 14' on page 14 and 'About your Li-Ion Battery' section on page 11.</p>
<p>Cannot activate VOX</p>	<p>VOX feature might not have been set to ON. Using CPS, make sure the VOX Sensitivity level is not set to 0. Accessory not working or not compatible. Refer to 'Hands-Free Use/VOX' section on page 28.</p>
<p>Battery doesn't charge although it has been placed in the drop-in charger for a while</p>	<p>Check drop-in charger is connected and correspond to a compatible power supply. Check you have the drop-in charger adjustable piece, placed on the right position (refer to 'Charging with the Drop-In Tray Single Unit Charger' and 'Charging a Stand-Alone Battery' section on page 18). Check the charger LEDs indicators to see if battery has a problem. Refer to 'Drop-in Tray Charger LED Indicators' section on page 21.</p>

Note: XTNI™ radios can also be programmed using the CPS. This special software can set up features or restrict values in the radio. Whenever a feature in the radio seems to not correspond to the default or preprogrammed values, check to see if the radio has been programmed using the CPS with a customized profile.

USE AND CARE

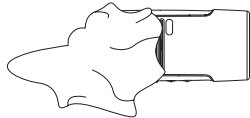

Use a soft damp cloth to clean the exterior



Do not immerse in water



Do not use alcohol or cleaning solutions

If the radio is submerged in water...

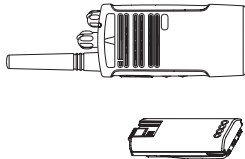

Turn radio OFF and remove batteries

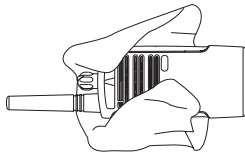

Dry with soft cloth

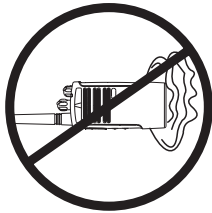

Do not use radio until completely dry

USE AND CARE

FREQUENCY AND CODE CHARTS

The charts in this section provide Frequency and Code information. These charts are useful

when using Motorola XTNi Series two-way radios with other business radios. Most of the frequency position are the same as Spirit M, GT, S, XTN Series Frequencies.

8 Channel Radios PMR 446 Defaults

Freq #	Frequency	Code	Bandwidth
1	446.00625	67.0 Hz	12.5kHz
2	446.01875	67.0 Hz	12.5kHz
3	446.03125	67.0 Hz	12.5kHz
4	445.04375	67.0 Hz	12.5kHz
5	446.05625	67.0 Hz	12.5kHz
6	446.06875	67.0 Hz	12.5kHz
7	446.08125	67.0 Hz	12.5kHz
8	446.09375	67.0 Hz	12.5kHz
9	446.00625	754.0 Hz	12.5kHz
10	446.01875	754.0 Hz	12.5kHz
11	446.03125	754.0 Hz	12.5kHz
12	445.04375	754.0 Hz	12.5kHz
13	446.05625	754.0 Hz	12.5kHz
14	446.06875	754.0 Hz	12.5kHz
15	446.08125	754.0 Hz	12.5kHz
16	446.09375	754.0 Hz	12.5kHz

Note: Code 754 corresponds to PL Code 121.

CTCSS

CTCSS		CTCSS		CTCSS	
CTCSS	Hz	CTCSS	Hz	CTCSS	Hz
1	67.0	14	107.2	27	167.9
2	71.9	15	110.9	28	173.8
3	74.4	16	114.8	29	179.9
4	77.0	17	118.8	30	186.2
5	79.7	18	123	31	192.8
6	82.5	19	127.3	32	203.5
7	85.4	20	131.8	33	210.7
8	88.5	21	136.5	34	218.1
9	91.5	22	141.3	35	225.7
10	94.8	23	146.2	36	233.6
11	97.4	24	151.4	37	241.8
12	100.0	25	156.7	38	250.3
13	103.5	26	162.2	122 (*)	69.3

Note: (*) New CTCSS code.

DPL Codes

DPL	Code
39	23
40	25
41	26
42	31
43	32
44	43
45	47
46	51
47	54
48	65
49	71
50	72
51	73
52	74
53	114
54	115
55	116
56	125
57	131
58	132
59	134
60	143

DPL	Code
61	152
62	155
63	156
64	162
65	165
66	172
67	174
68	205
69	223
70	226
71	243
72	244
73	245
74	251
75	261
76	263
77	265
78	271
79	306
80	311
81	315
82	331

DPL	Code
83	343
84	346
85	351
86	364
87	365
88	371
89	411
90	412
91	413
92	423
93	431
94	432
95	445
96	464
97	465
98	466
99	503
100	506
101	516
102	532
103	546
104	565

DPL Codes (cont.)

DPL	Code
105	606
106	612
107	624
108	627
109	631
110	632
111	654

DPL	Code
112	662
113	664
114	703
115	712
116	723
117	731
118	732

DPL	Code
119	734
120	743
121	754

MOTOROLA LIMITED WARRANTY

MOTOROLA LIMITED WARRANTY

WARRANTY INFORMATION

The authorised Motorola dealer or retailer where you purchased your Motorola two-way radio and/or original accessories will honour a warranty claim and/or provide warranty service. Please return your radio to your dealer or retailer to claim your warranty service. Do not return your radio to Motorola. To be eligible to receive warranty service, you must present your receipt of purchase or a comparable substitute proof of purchase bearing the date of purchase. The two-way radio should also clearly display the serial number. The warranty will not apply if the type or serial numbers on the product have been altered, deleted, removed, or made illegible.

WHAT IS NOT COVERED BY THE WARRANTY

- Defects or damage resulting from use of the Product in other than its normal and customary manner or by not following the instructions in this user manual.
- Defects or damage from misuse, accident or neglect.
- Defects of damage from improper testing, operation, maintenance, adjustment, or any alteration or modification of any kind.
- Breakage or damage to aereals unless caused directly by defects in material or workmanship.
- Products disassembled or repaired in such a manner as to adversely affect performance or prevent adequate inspection and testing to verify any warranty claim.

MOTOROLA LIMITED WARRANTY

- Defects or damage due to range.
- Defects or damage due to moisture, liquid or spills.
- All plastic surfaces and all other externally exposed parts that are scratched or damaged due to normal use.
- Products rented on a temporary basis.
- Periodic maintenance and repair or replacement of parts due to normal usage, wear and tear.

ACCESSORIES

AUDIO ACCESSORIES

Part No.	Description
00115	Remote Speaker Mic BR
00168	Lightweight headset
00117	Headset w/Swivel Boom Mic
00118	Earbud w/Clip PTT Mic BR

BATTERY

Part No.	Description
RLN6306	Alkaline Battery Frame
RLN6351	Standard Li-Ion Battery
RLN6305	High Capacity Li-Ion Battery

CARRY ACCESSORIES

Part No.	Description
RLN6302	Hard Leather Carry Case
RLN6307	Spring Action Belt Clip

SOFTWARE APPLICATIONS

Part No.	Description
IXEN4007 AR	Computer Programming Software (CPS) and Programming Cable

CABLES

Part No.	Description
RLN6303	Radio To Radio Cable

CHARGERS

Part No.	Description
IXPN4019 AR	Rapid Charging Kit - European (**)
IXPN4020 AR	Multi-Unit Charger (MUC) Kit - European

Note:

(*) **Attention:** Certain accessories may be or may not be available at the time of purchase. Please contact your Motorola point of purchase or visit www.motorola.com/XTNi or www.motorola.com/radios/business for latest information on accessories.

(**) European Rapid Charging Kit includes Power Supply, Drop-in Tray Charger, and AC Pin adaptors. Certain accessories may be or not available at the time of purchase. Please contact your Motorola Point of Purchase or visit www.motorola.com/XTNi or www.motorola.com/radios/business for latest information on accessories.

Contact your Motorola authorized dealer for availability and accessories new models information

ACCESSORIES

MOTOROLA, the Stylized M Logo,XTNi Series and all other trademarks indicated as such herein are trademarks of Motorola, Inc. ® Reg. U.S. Pat. & Tm. Off. All other product or service names are the property of their respective owners. © 2007 Motorola, Inc. All rights reserved.

Motorola® XTNi Series



6871663M06-A

